

## Description

- The locking point is a special roller cam designed to reduce friction  
The construction of the corner transmission allows you to cut even (equal) the gear front plate and guide rod (no special tool required) but also allows you to punch a hole for an additional screw (pneumatic cutting machine required). This way, the connection between the corner transmission and the gear is no longer mobile and the reliability of the system is increased.
- Easy ventilation advantage with usage T-19182 and T-19183 ventilation locking plates.
- The length of the corner transmission is 135 mm
- The connection between the corner transmission and the guiding rod of the gear is made of drawn steel
- The transmission is realized with 3 stainless steel springs in the guide.



## Material Specification

Body : Steel acc. EN 10149  
 Surface : Corrosion resistance up to 500 hours acc. DIN 50021

## Technical Drawing

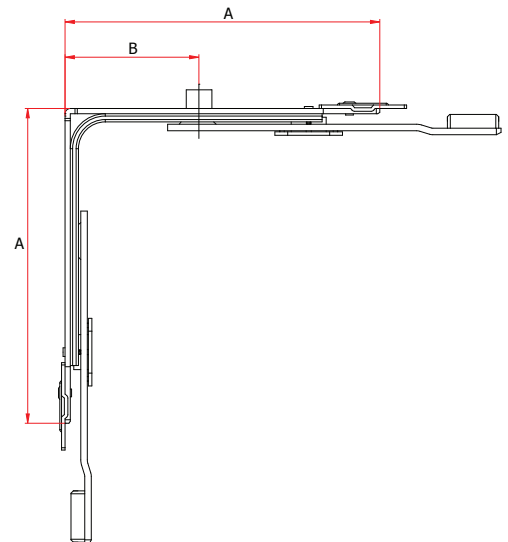
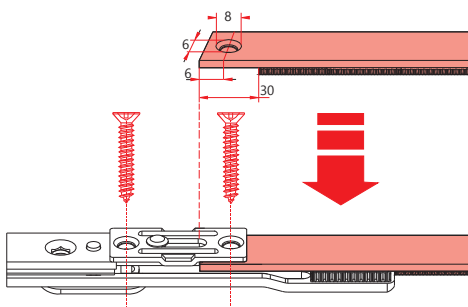

PG	Code	A	B		
T1	T-10181-00-0-1	135	57	1	20